

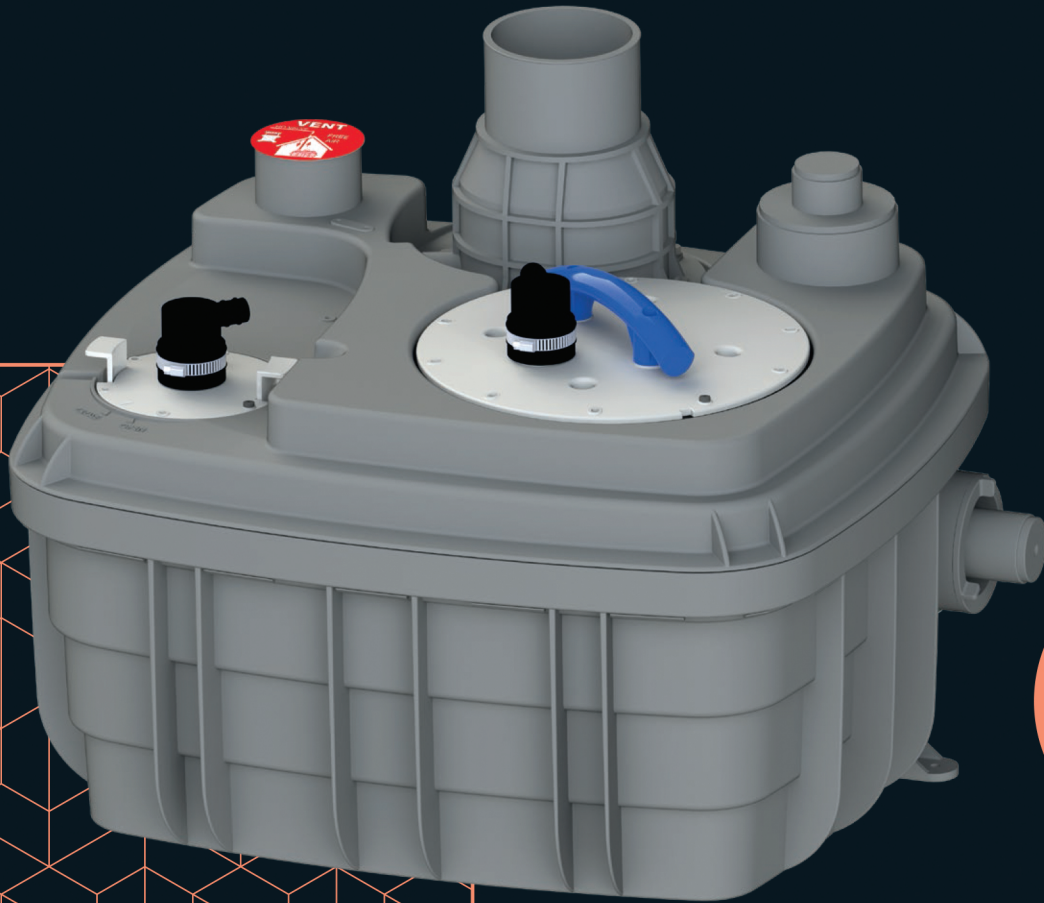

SANICUBIC® 1 VX

SEWAGE LIFTING UNIT



Vortex KX V6

SEWAGE
shops, restaurants

13 m
↑

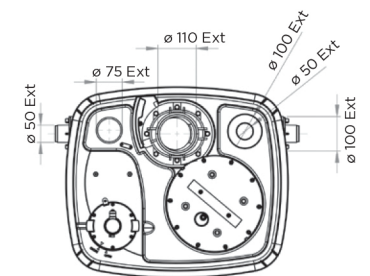
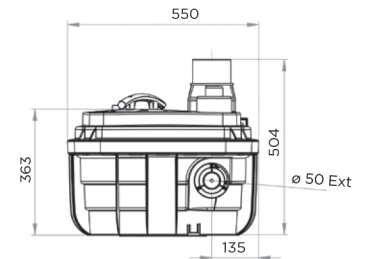
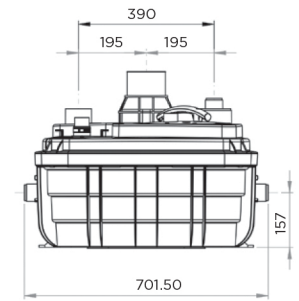

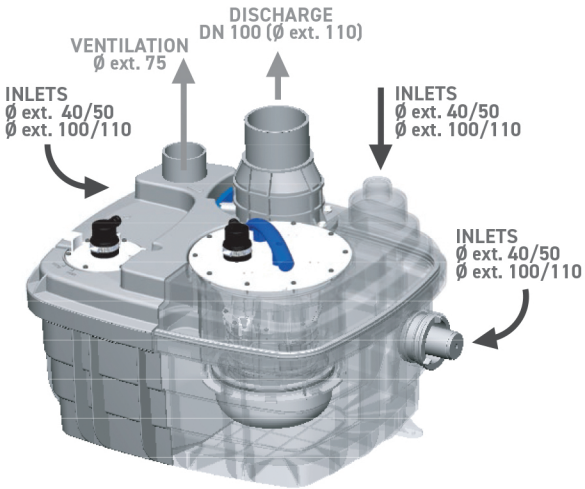
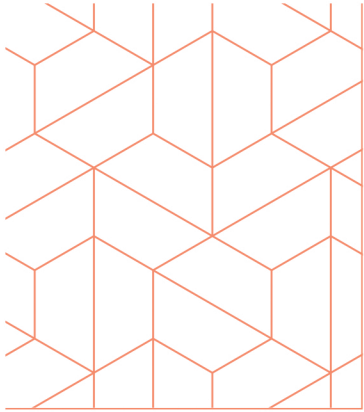

BENEFITS

- High performance: 1 Vortex pump in single phase & several inlets
- Wired remote control and external alarm unit
- Direct and secure access to the pump
- Accessories: isolation valves and carbon air filter

APPLICATIONS

- Pumping of sewage from shops and single-family houses
- For installation inside buildings

ISOLATION VALVE

DN50: EAN 3308815061030
 DN100: EAN 3308815061023



CARBON AIR FILTER

EAN 3308815076867



FEATURES

- Materials Polyethylene
- Max. temperature of incoming waste water 70°C intermittently (max. 5 min.)
- ON/OFF level 165/65 mm
- Alarm level 230 mm
- Activation pressure system

PUMP GRAPH

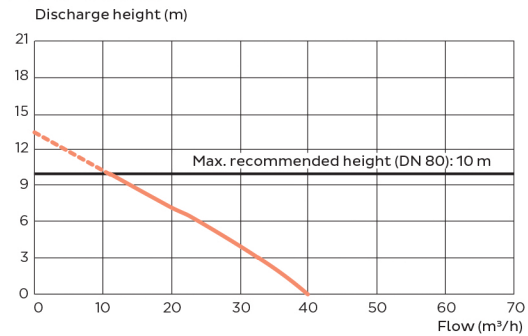

REFERENCE	EAN	FACTORY CODE	SYSTEM	TANK (L)	SWITCHING VOLUME (L)	U (V)	P (W)	FREQUENCY (HZ)	I MAX (A)	TR / MN	POWER CLASS	Q MAX (M³/H)	H MAX (M)	WEIGHT (KG)	REMOTE CONTROL	POWER CLASS CONTROL	ALARM
SANICUBIC 1VX S	3 308 815 077 611	CUBIC1XLVX	Vortex	60	20	230	2,000	50/60	8	2,800	IP 68	40	13	30	Classic	IP X4	External, wired